



فرست اوتوماشن

Marking Light

Series CZ0264/20



Prodcuts Features

- AC 100-250V 50/60Hz for power supply.
- Explosion-proof LED marking light.
- Explosion-proof LED emergency marking light, emergency time 120min.
- Emergency type has indicator for fault, charging and discharge.
- Emergency types have maintained and non-maintained type. Maintained type can work when either normal power on or emergency power on. Non-maintained type can only work when emergency power on.
- 16 labels for options, others are also available on request.
- IECEx and ATEX certified.





فرست اوتوماشن

Marking Light

Series CZ0264/20



Product Parameter

Product type:	Explosion-proof LED (emergency) marking light
Certification:	CCCF
Application range (zones):	2G/Gb/zone 1; 2D/Db/zone 21
Min.ambient temperature:	-20°C
Max.ambient temperature:	+55°C
Degree of protection:	IP66
Rated voltage:	AC100 ~ 250V 50/60Hz
Emergency starting time:	≤0.1S
Emergency illuminating time:	120min



فرست اوتوماشن

Marking Light

Series CZ0264/20



- 防爆标志灯由高品质的全塑外壳制成，防护等级IP66，适用于户内外等各种适用的环境

本安电路防爆标志：

Ex db eb ib mb op is q II C T4 Gb Ex tb III C T80°C Db

可用于 1 区和 2 区； 21 区和 22 区

宽电压 AC100 ~ 250V 50/60Hz

LED光源，电子元件设计使用寿命（50000小时）

应急灯带有三颗LED指示灯，显示故障状态

- The explosion-proof marking light have good quality plastic housings, with degree of protection IP66. They are suitable for indoor or outdoor use.

Ex-marking for Ex i circuit:

Ex db eb ib mb op is q II C T4 Gb Ex tb III C T80°C Db

Can be used in zone 1 and zone 2, zone 21 and zone 22

Wide voltage range: AC100 ~ 250V 50/60Hz

Designed life of LEDs and electronics is 50000 hours

Emergency version has three LED signal lamps inside indicating any fault if there is.



- LED光源前端有导光板，使灯具光源更加柔和
- 可更换内置式标识牌，在透明罩PC保护下不受外界雨水和粉尘影响，标识牌识别距离可达30米

- There is light guide plate in front of LEDs to make the light be more soft.
- Built-in pictograms can be replaced, and are visible 30m with PC transparent cover protected from rain and dust.



فرست اوتوماشن





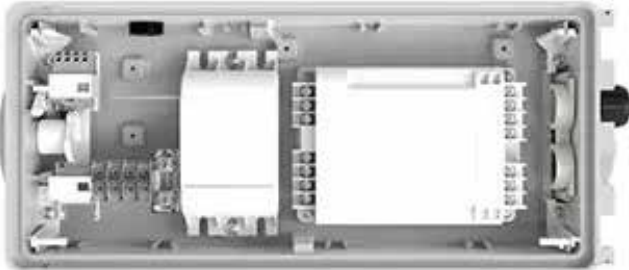











Marking Light

Series CZ0264/20



- 可选防爆熔断器和防爆行程开关模块
- 专用的防爆应急电源模块，具有过压保护、过载保护、恒流输出
- 电池模块循环充放电次数≥500次
- Optional explosion-proof isolation switch and fuse.
- Special explosion-proof emergency power supply modules have the functions of over voltage protection, over load protection and constant current output.
- Circulating charge and discharge of battery module is more than 500times.

Order specifications

Illustration	Power	Surface brightness	Order No.
	3W	50cd/m ² ~ 300cd/m ²	CZ0264/20-LED3W-1□-□-B
Mark code (Optional)			
			
Code: 80	Code: 84	Code: 88	Code: 92
			
Code: 81	Code: 85	Code: 89	Code: 93
			
Code: 82	Code: 86	Code: 90	Code: 94
			
Code: 83	Code: 87	Code: 91	Code: 95
K: Explosion-proof limit switch module KF: Explosion-proof limit switch module, Explosion-proof fuse module			Optional
For code of cable gland, see page C/37			



فرست اوتوماشن

Marking Light

Series CZ0264/20



Order specifications

Illustration	Power	Surface brightness	Operating mode	Order No.
	3W	50cd/m ² ~ 300cd/m ²	Maintained	CZ0264/20-LED3W-M-1□-□-B
	3W	50cd/m ² ~ 300cd/m ²	Non maintained	CZ0264/20-LED3W-NM-1□-□-B

Mark code (Optional)

K: Explosion-proof limit switch module
 KF: Explosion-proof limit switch module, Explosion-proof fuse module

Optional

For code of cable gland, see page C/37

Order specifications

Illustration	Power	Luminous flux	Order No.
	3W	160lm	CZ0264/20-LED3W-□-B

K: Explosion-proof limit switch module
 KF: Explosion-proof limit switch module, Explosion-proof fuse module

Optional

For code of cable gland, see page C/37



















فرست اوتوماشن

Marking Light

Series CZ0264/20



Order specifications

Illustration	Power	Surface brightness	Order No.
	3W	50cd/m ² ~ 300cd/m ²	CZ0264/20-LED3W-2-□-□- B
Mark code (Optional)			
 Code: 80	 Code: 84	 Code: 88	 Code: 92
 Code: 81	 Code: 85	 Code: 89	 Code: 93
 Code: 82	 Code: 86	 Code: 90	 Code: 94
 Code: 83	 Code: 87	 Code: 91	 Code: 95
<p>K: Explosion-proof limit switch module</p> <p>KF: Explosion-proof limit switch module, Explosion-proof fuse module</p>			<p>Optional</p>

Order specifications

Illustration	Power	Luminous flux	Operating mode	Order No.
	3W	160lm	Maintained	CZ0264/20-LED3W-M-□-□- B
	3W	160lm	Non maintained	CZ0264/20-LED3W-NM-□-□- B
<p>K: Explosion-proof limit switch module</p> <p>KF: Explosion-proof limit switch module, Explosion-proof fuse module</p>			<p>Optional</p>	
				<p>For code of cable gland, see page C/37</p>



فرست اوتوماشن

Marking Light

Series CZ0264/20



Accessories



Explosion-proof limit switch module

Order No: CZ0207-1

Type of protection:

II 2G Ex db eb IIC Gb

Contact: 2NC (2NC)

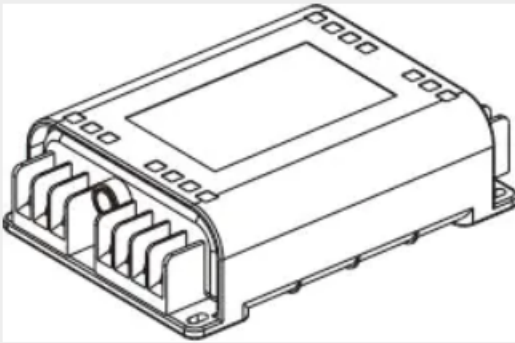

Explosion-proof fire
emergency marking
luminaire battery module

Order No: CZ1618/BLJC-3W

Type of protection: Ex eb q IIC Gb

Power:3W

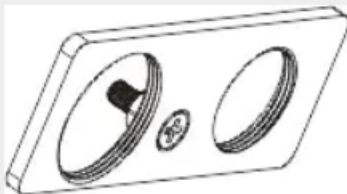

Earthing nut

Order No: D8714/2-M20

Order No: D8714/2-M25



فرست اوتوماشن

Marking Light

Series CZ0264/20



Accessories

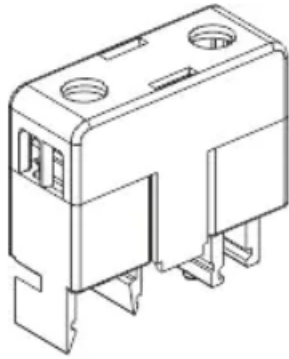

Explosion-proof fuse module

Order No: CZ0804/T0.8A

Order No: CZ0804/1.25A

Order No: CZ0804/T6.3A

Type of protection:

II 2G Ex e mb II C Gb

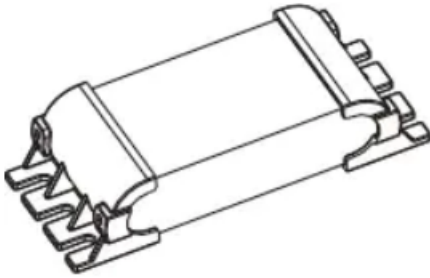

Explosion-proof battery module

Order No: CZ0819/1.0Ah/3.6V

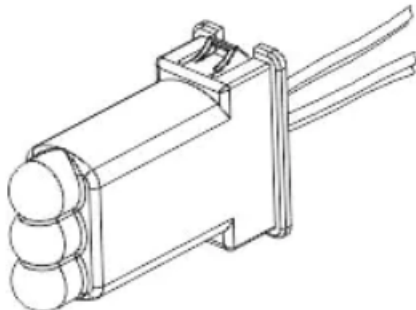

Explosion-proof emergency
indicator module

Order No: CZ0802/1