



فرست اوتوماشن

Emergency Light

Series CZ0865/0866



Prodcuts Features

- Full plastic explosion-proof fluorescent light fittings mounting ways: Ceiling type, chain type, pendant type, wall type and clamp type.
- Full plastic explosion-proof fluorescent light fittings (polemounting) mounting ways: Platform fence type, platform flange type, wall type.
- Standard two-supply circuit design and EOL switching off function design when the life of the lamp tube is end;
- With trichromatic lamp tubes inside to have high luminous efficiency and long life.
- With interlock device, the transparent parts and enclosure can not energize to work to ensure safe use before completely sealing.
- The explosion-proof ballast is equipped with the protective functions of open circuit, short circuit and abnormality of lamp tube;
- The structural design is never distortion and its protection degree is up to IP66.
- International IECEx Approval, Europe union ATEX Approval.





فرست اوتوماشن

Emergency Light

Series CZ0865/0866



Product Parameter

Product type:	Full plastic explosion-proof emergency fluorescent light fittings (Pole Mounting)
Certification:	CCC IECEX ATEX
Application range (zones):	2G/Gb/zone 1; 2D/Db/zone 21
Min.ambient temperature:	T83°C: -25°C T98°C: -25°C
Max.ambient temperature:	T83°C: +40°C T98°C: +55°C
Degree of protection:	IP66
Rated voltage:	110 ~ 240V AC (±10%) 50/60Hz
Energy efficiency index:	EEI=A2
Power factor:	$\lambda > 0.95$



فرست اوتوماشن

Emergency Light

Series CZ0865/0866



Mounting circuit diagram for emergency light fittings

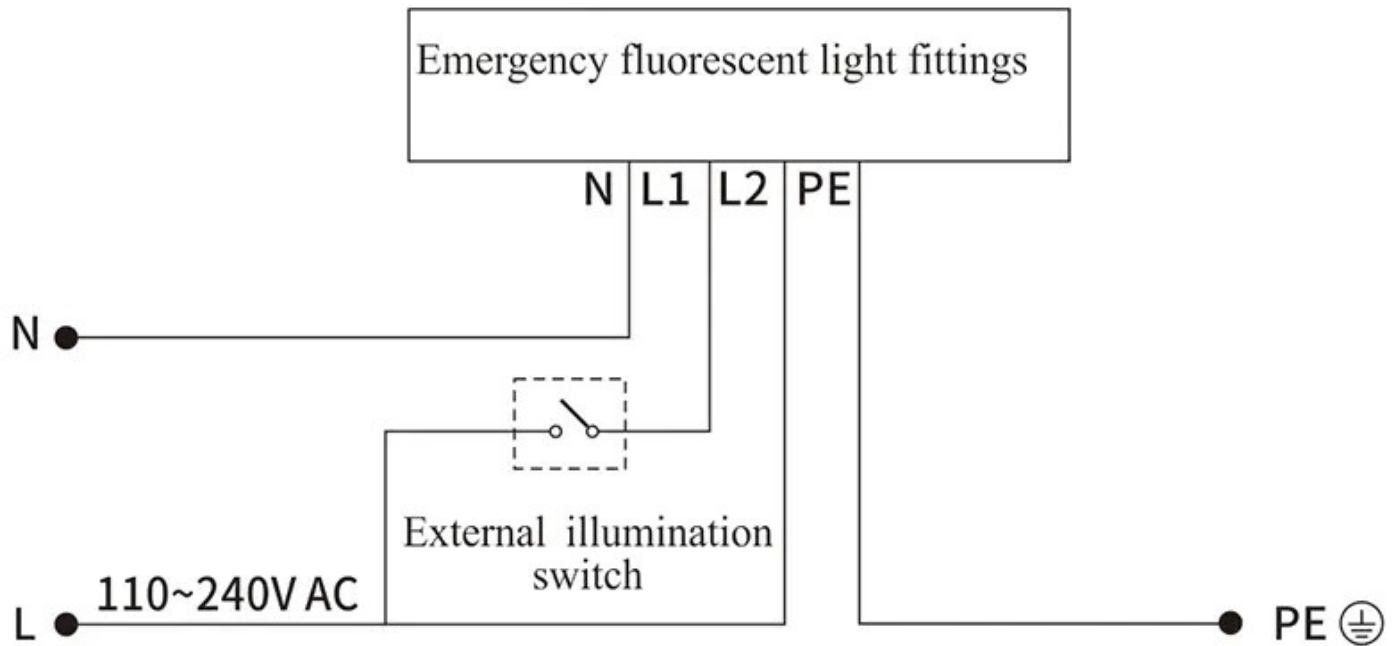

CZ0865, CZ0866
full plastic explosion-proof
(emergency) fluorescent light fittings



CZ0865, CZ0866
full plastic explosion-proof
(emergency) fluorescent
light fittings (Pole mounting)



فرست اوتوماشن

Emergency Light

Series CZ0865/0866

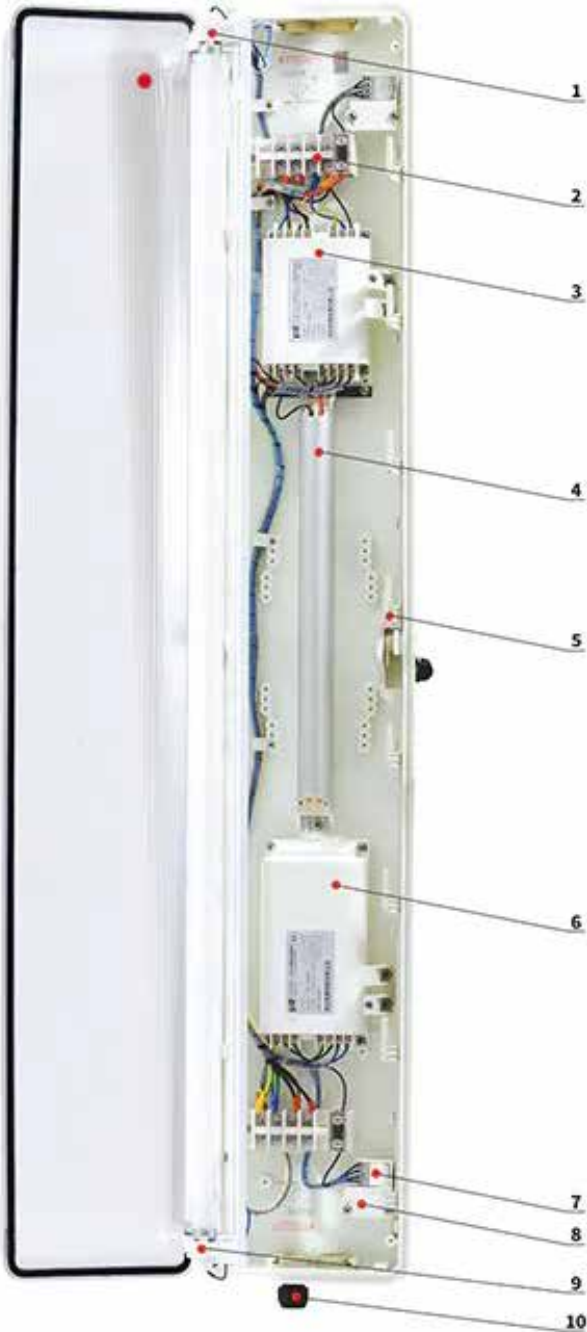

Explosion-proof lampholder of Ex e II (Two-pin) G5, G13.



Explosion-proof terminal module of Ex e II.



The reliable service quality and security of the electrical apparatus is guaranteed by the explosion-proof inverter module.



The explosion-proof battery module is thermostable and high-capacity.



The enclosure and transparent shield are pressed tightly and drive the switching off and interlocking function of explosion-proof isolation switch by interlocking device through interlocking mechanism.



The reliable service quality and security of the electrical apparatus is guaranteed by the explosion-proof ballast module.



The explosion-proof isolation switch module of Ex de IIC is operated by interlocking device and the enclosure can only be opened when the switch is off.



With interlocking device, it can't be energized when the transparent shield and enclosure are not closed or sealed completely to ensure the security of use.



The explosion-proof emergency signal lamp module and three kinds of signal indicators.



RUCs, ATEX certified cable gland and stopping plug of Ex e II.

CZ0865、 CZ0866 YJ

Full plastic explosion-proof emergency fluorescent light fittings

Contact

info@first-automation.com.eg/ • 01101619222 – 01100200886 • https://first-automation.com.eg/



فرست اوتوماشن

Emergency Light

Series CZ0865/0866

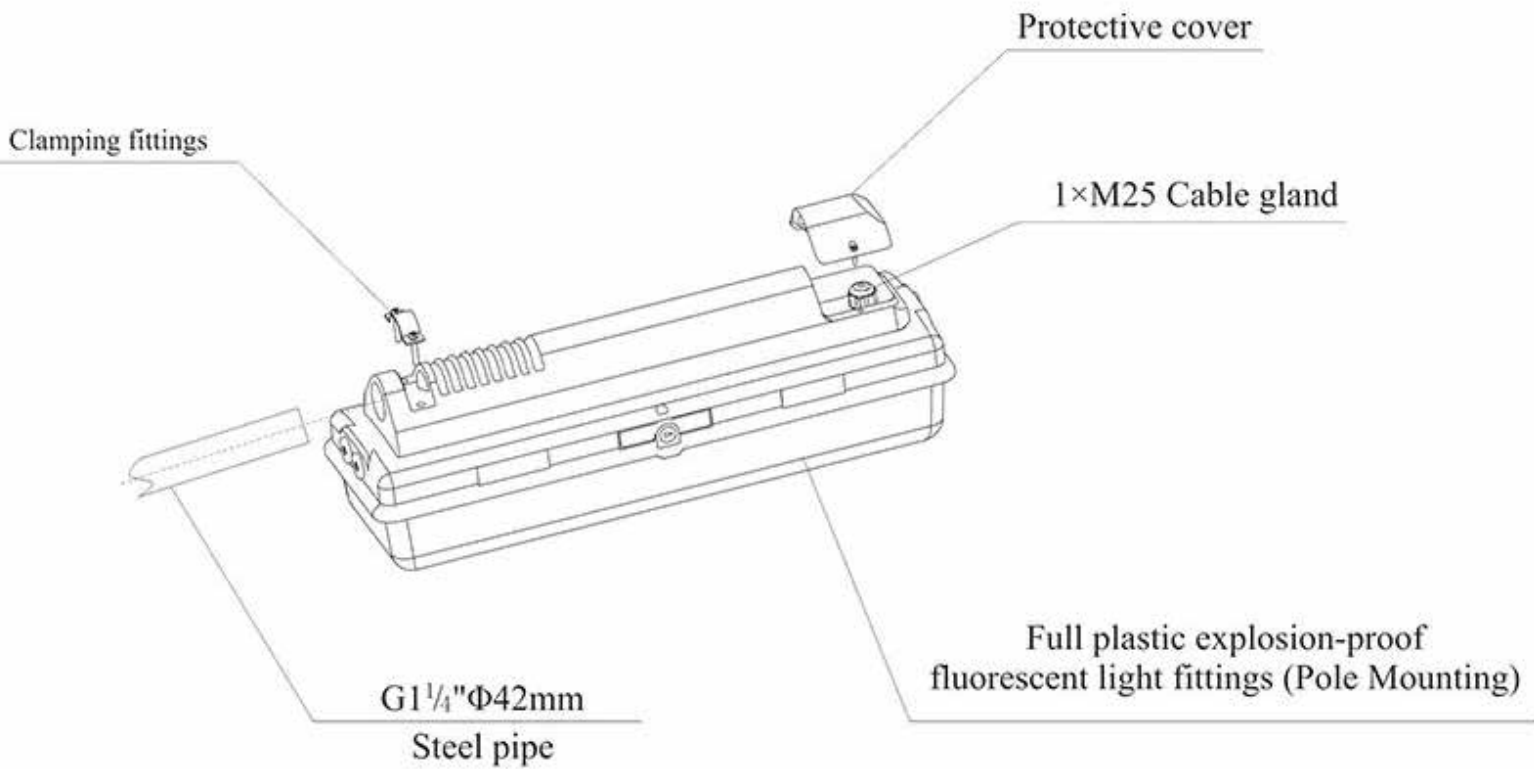



فرست اوتوماشن

Emergency Light

Series CZ0865/0866

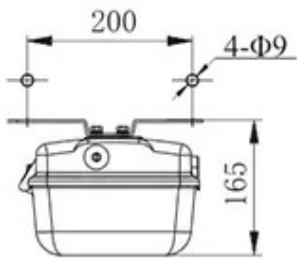

Ceiling type

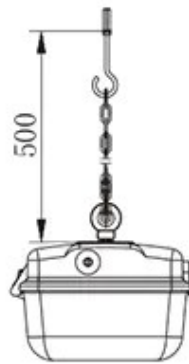

Chain type

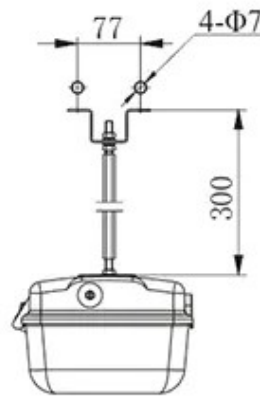

Pendant type

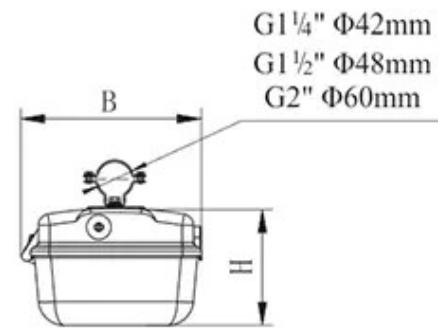

Clamp type

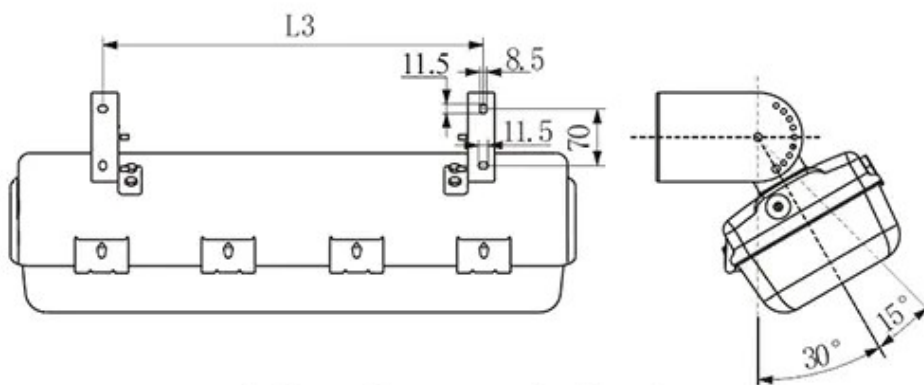

Adjustable mounting bracket



فرست اوتوماشن

Emergency Light

Series CZ0865/0866

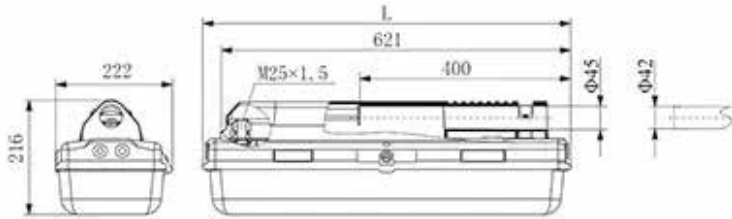

Unit:mm

Type	L	L1	L2	H1	H2
CZ0865	698	850	815	2635	2645
CZ0866	1310	1440	1405	2740	2750

Full plastic explosion-proof (emergency) fluorescent light fittings (Pole Mounting)

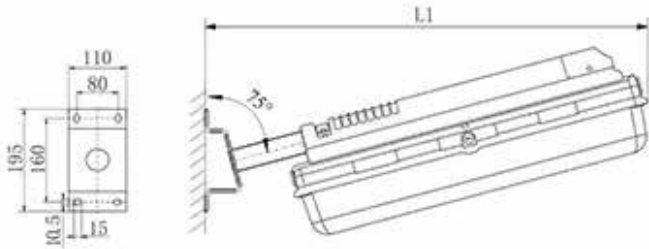

D8739
Wall mounting bracket of pole type

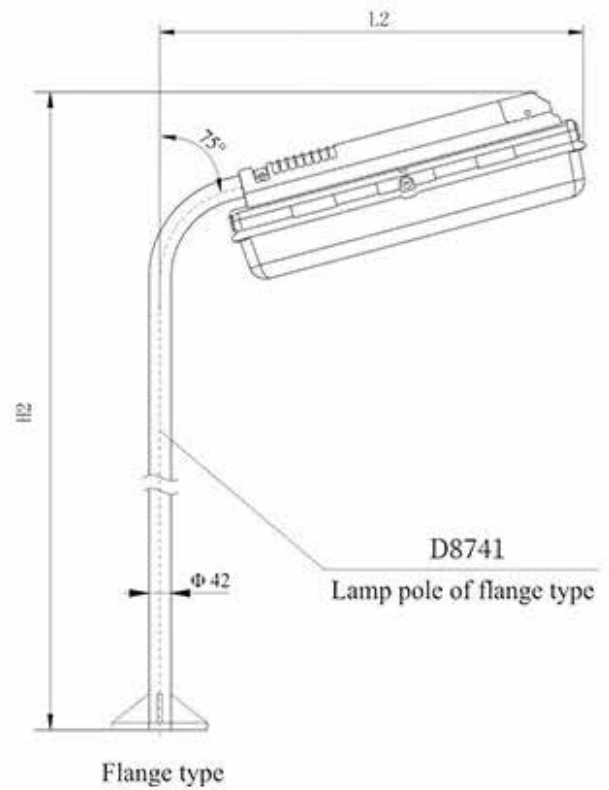
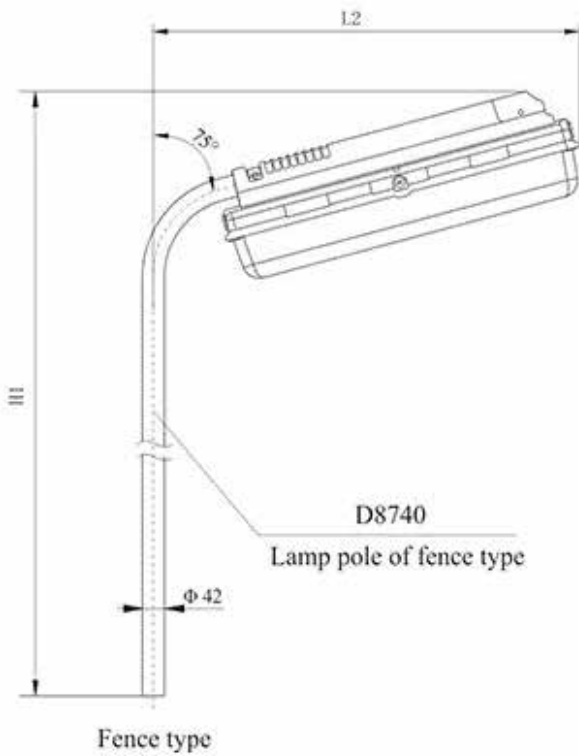



فرست اوتوماشن

Emergency Light

Series CZ0865/0866



Unit:mm

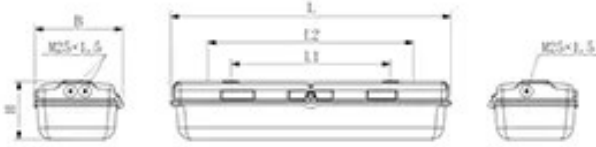

Full plastic explosion-proof (emergency) fluorescent light fittings

Type	CZ0865	CZ0866
L	698	1310
L1	400	800
L2	550	1100
L3	470	870
L4	800	1300
B	222	222
H	145	145
H1	2510	2510
H2	2500	2500
H3	1050	1050

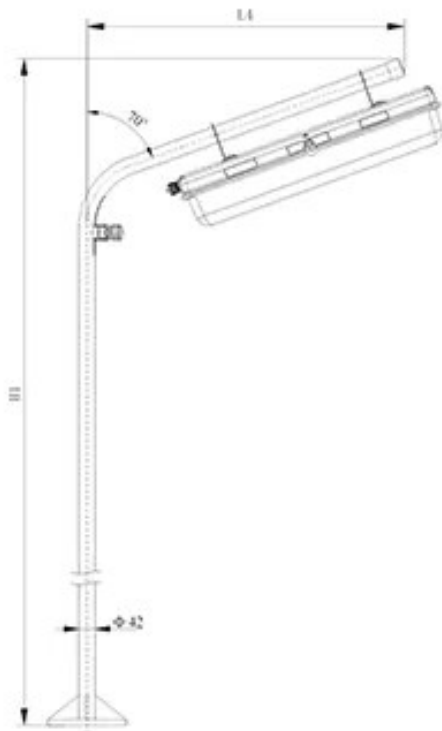

Flange type

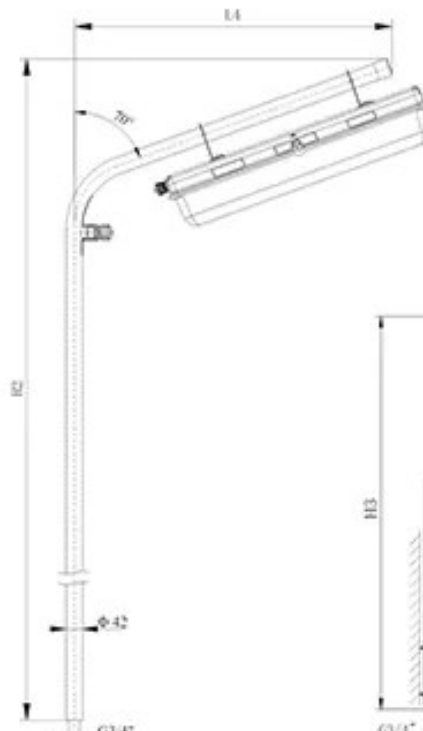

Fence type

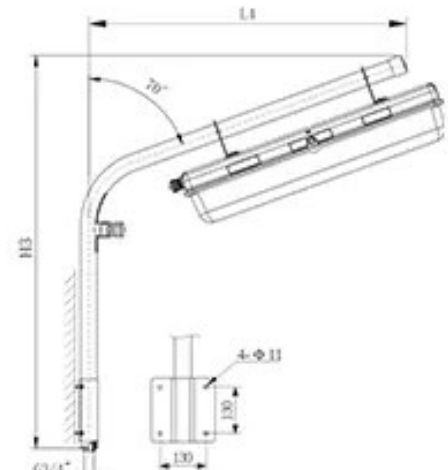

Wall type

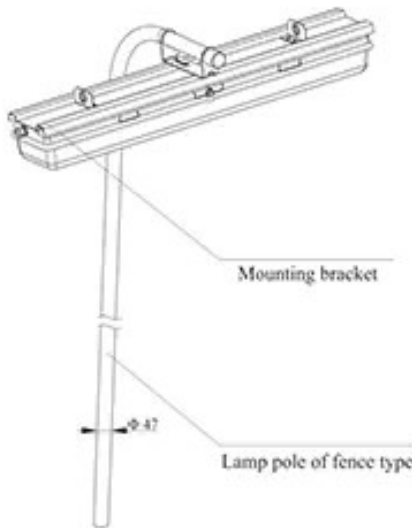

Fence type

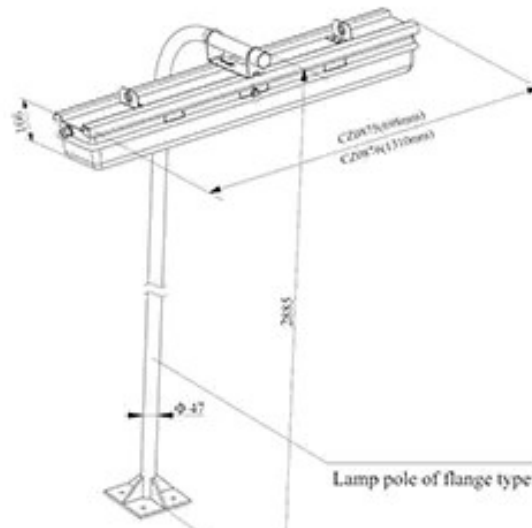

Flange type



فرست اوتوماشن

Emergency Light

Series CZ0865/0866



Illustration

Order No.



Full plastic explosion-proof emergency fluorescent light fittings

CZ0865 / 2 × 14W-1 YJ-B+

CZ0866 / 2 × 28W-1 YJ-B+

CZ0865 / 2 × 18W-1 YJ-B+

CZ0866 / 2 × 36W-1 YJ-B+



Full plastic explosion-proof emergency fluorescent light fittings (Pole mounting)

CZ0865 / 2 × 14W-1 YJ-PM+

CZ0866 / 2 × 28W-1 YJ-PM+

CZ0865 / 2 × 18W-1 YJ-PM+

CZ0866 / 2 × 36W-1 YJ-PM+

Contact

info@first-automation.com.eg/ • 01101619222 – 01100200886 • https://first-automation.com.eg/



فرست اوتوماشن

Emergency Light

Series CZ0865/0866



Optional Ex components



| CZ0220 Series Plastic stopping plugs, the reducer



| CZ0221 Metal cable glands



| CZ0220 Series Plastic cable glands, stopping plugs



| CZ0226 Increased safety cable glands



| CZ0527, CZ1725/27 Increased safety breathing, drainage valve



| CZ0227 Increased safety metal cable glands



| CZ1725/1C Metal cable glands



| CZ1725/2A Metal cable glands



| CZ1725/3A Metal stopping plug



| CZ1725/1A Metal cable glands



| CZ1725/4A The reducer



| CZ1725/1B Metal cable glands



فرست اوتوماشن

Emergency Light

Series CZ0865/0866



Accessories

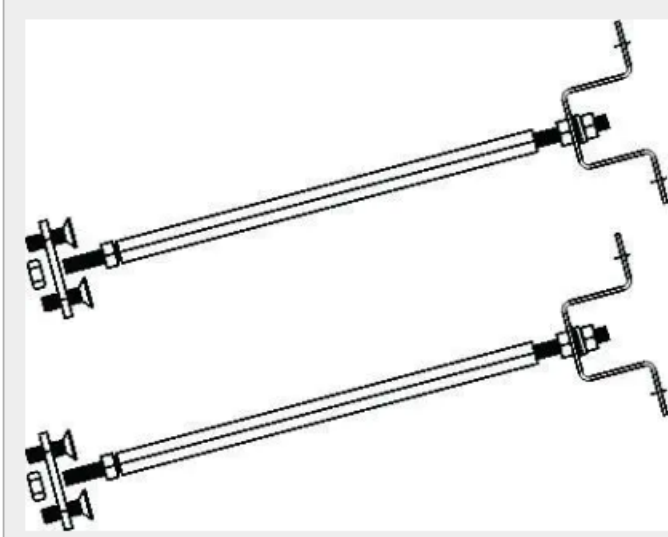

Accessories for
pendant type
D622

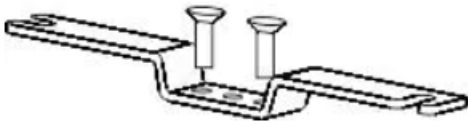
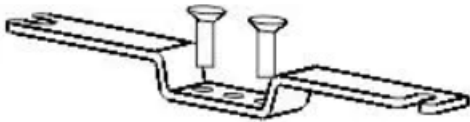

Support for ceiling type

Steel, Stainless steel

D621, D621/304



فرست اوتوماشن

Emergency Light

Series CZ0865/0866



Accessories

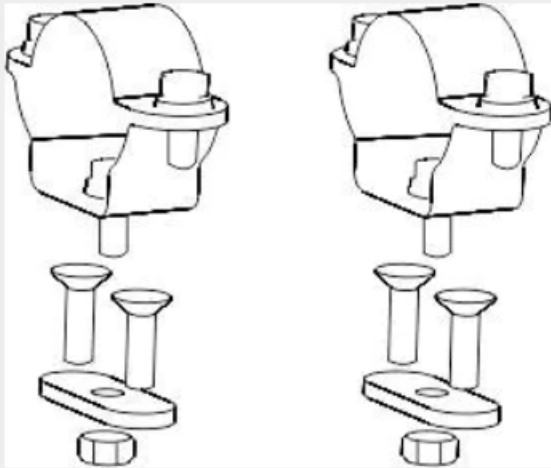

Accessories for clamp
type M8 bolt mounting

J200: G1 1/4"Φ42mm Steel

J200/304: G1 1/4"Φ42mm Stainless steel

J300: G1 1/2"Φ48mm Steel

J300/304: G1 1/2"Φ48mm Stainless steel

J400: G2"Φ60mm Steel

J400/304: G2"Φ60mm Stainless steel

J200、J200/304;J300、J300/304;J400、J400/304



Accessories for
chain type
D623



فرست اوتوماشن

Emergency Light

Series CZ0865/0866



Accessories

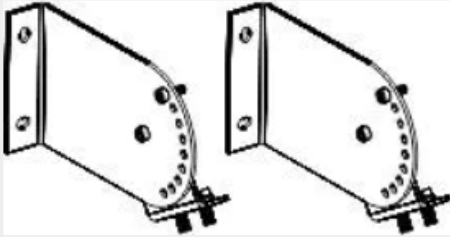

Adjustable
mounting bracket

D8738

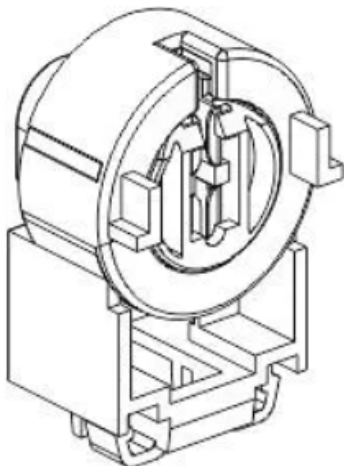

Explosion-proof lampholder

CZ0403/G5:Explosion-proof G5 lampholder, used for

T5

fluorescent lamp tube of energy saving type

CZ0403/G13:Explosion-proof G13 lampholder, used

for T8

fluorescent lamp tube of energy saving type

CZ0403/G5

CZ0403/G13



فرست اوتوماشن

Emergency Light

Series CZ0865/0866



Accessories

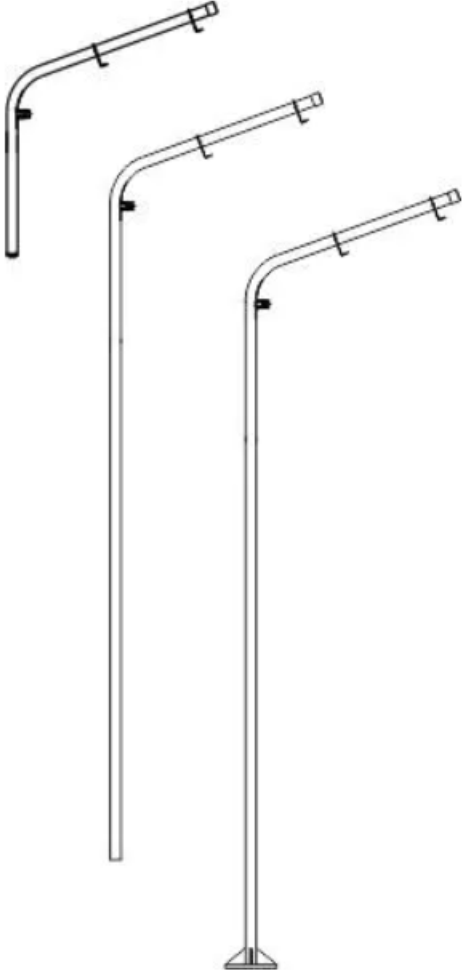

Lamp pole of wall type:

D8709/1A Used for CZ0865 LED linear light fittings

D8709/2A Used for CZ0866 LED linear light fittings

Lamp pole of fence type:

D8710/1A Used for CZ0865 LED linear light fittings

D8710/2A Used for CZ0866 LED linear light fittings

Lamp pole of flange type:

D8711/1A Used for CZ0865 LED linear light fittings

D8711/2A Used for CZ0866 LED linear light fittings

D8709, D8710, D8711



Explosion-proof isolation

switch module

CZ0207-1



فرست اوتوماشن

Emergency Light

Series CZ0865/0866



Accessories

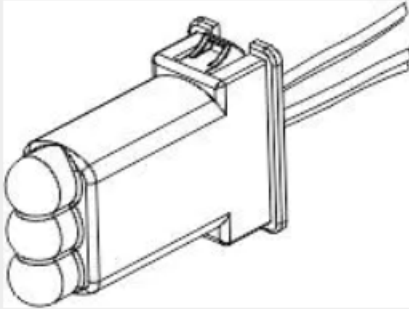

Explosion-proof emergency
indicator module

Three colors for LED: red, yellow, green
CZ0802/1

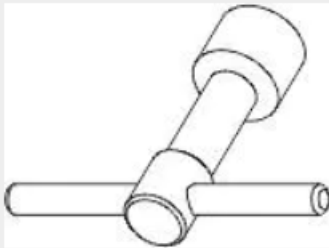

M8/SW13 Sleeve spanner

Used for CZ0865, CZ0866,
Material: Fine quality steel with galvanized surface
D601

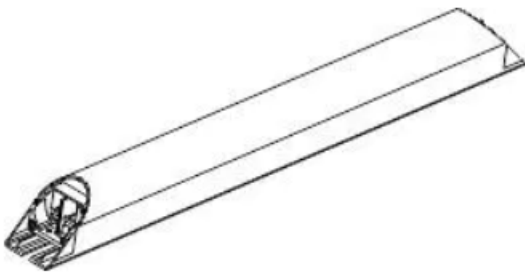

Explosion-proof battery module

CZ0819/4.5Ah 6V
CZ0819/4.5Ah 7.2V

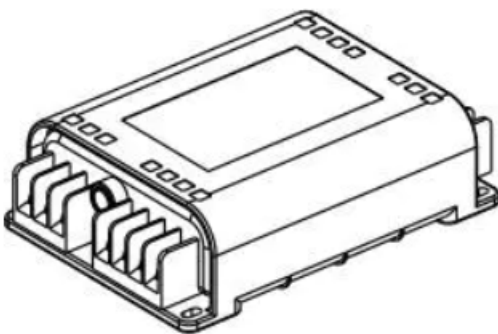

Explosion-proof inverter module

CZ0818/1×18W(14W)-1 YJ: Emergency power:
1×18W, 1×14W

CZ0818/1×36W(28W)-1 YJ: Emergency power:
1×36W, 1×28W

CZ0818/1×18W(14W)-1 YJ
CZ0818/1×36W(28W)-1 YJ



فرست اوتوماشن

Emergency Light

Series CZ0865/0866

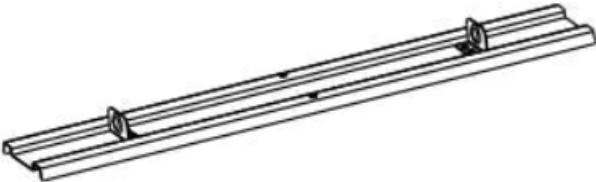
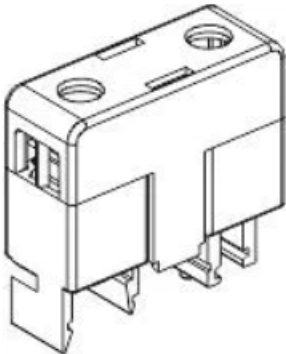

Accessories

	<p>Lamp pole of fence type: D8740 Use for pole mounting linear light fittings</p> <p>Lamp pole of flange type: D8741 Use for pole mounting linear light fittings</p> <p>D8740、D8741</p>
	<p>Mounting bracket</p> <p>D8742/1 Used for CZ0865 LED linear light fittings</p> <p>D8742/2 Used for CZ0866 LED linear light fittings</p> <p>D8742/1、D8742/2</p>
	<p>Explosion-proof fuse module</p> <p>CZ0804/T0.8A</p> <p>CZ0804/T1.25A</p> <p>CZ0804/T6.3A</p> <p>CZ0804</p>



فرست اوتوماشن

Emergency Light

Series CZ0865/0866



Accessories

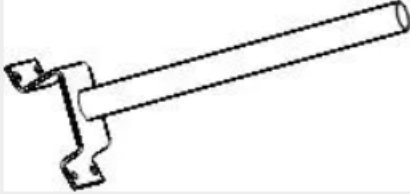

Wall mounting
bracket of pole type

Use for pole mounting linear light fittings
D8739

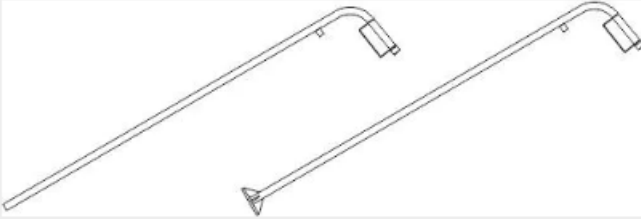

Lamp pole of fence type: D8705
Lamp pole of flange type: D8706
D8705, D8706

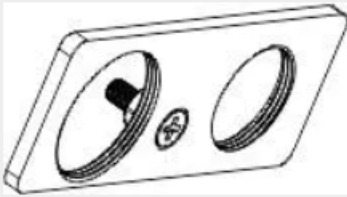

Metal earthing nut 2-M25x1.5
D8714/2-M25



فرست اوتوماشن

Emergency Light

Series CZ0865/0866



Accessories

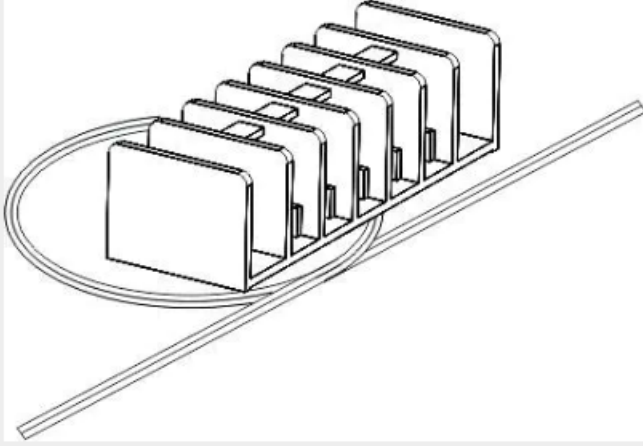

With conductor terminal board

305/21: 1×LED 30W

305/22: 2×LED 30W

3P terminal, Conductor 3×2.5mm²

max16A, L1+N+PE

305/31: 1×LED 30W

305/32: 2×LED 30W

4P terminal, Conductor 4×2.5mm²

max16A, L1+L2+N+PE

305



فرست اوتوماشن

Emergency Light

Series CZ0865/0866



Accessories

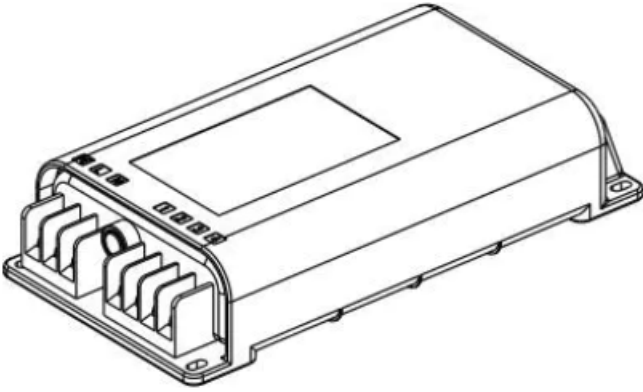

Explosion-proof ballast module

CZ0818/2×14W-1

Power: 2×14W, used for T5 energy saving type fluorescent light fittings

CZ0818/2×28W-1

Power: 2×28W, used for T5 energy saving type fluorescent light fittings

CZ0818/2×18W-1

Power: 2×18W, used for T8 energy saving type fluorescent light fittings

CZ0818/2×36W-1

Power: 2×36W, used for T8 energy saving type fluorescent light fittings

CZ0818/2×14W-1

CZ0818/2×28W-1

CZ0818/2×18W-1

CZ0818/2×36W-1