



فرست اوتوماشن

# LED Marking Light

Series CZ0264 /31



## Products Features

- Emergency versions have signal lamps indicating fault if there is, charging and discharging.
- Explosion-proof isolation switch and explosion-proof fuse are optional.
- IECEx and ATEX certified.

## Product Parameter

<b>Product type:</b>	Explosion-proof LED marking light
<b>Certification:</b>	CCC IECEX ATEX
<b>Application range (zones):</b>	2G/Gb/zone 1; 2D/Db/zone 21
<b>Min.ambient temperature:</b>	-25°C
<b>Max.ambient temperature:</b>	+50°C
<b>Degree of protection:</b>	IP5
<b>Rated voltage:</b>	AC100 ~ 250V 50/60Hz
<b>Rated current:</b>	Max 0.15A
<b>Weight:</b>	3.36kg



فرست اوتوماشن

# LED Marking Light

Series CZ0264 /31



Contact

info@first-automation.com.eg/ • 01101619222 – 01100200886 • <https://first-automation.com.eg/>



فرست اوتوماشن

# LED Marking Light

Series CZ0264 /31

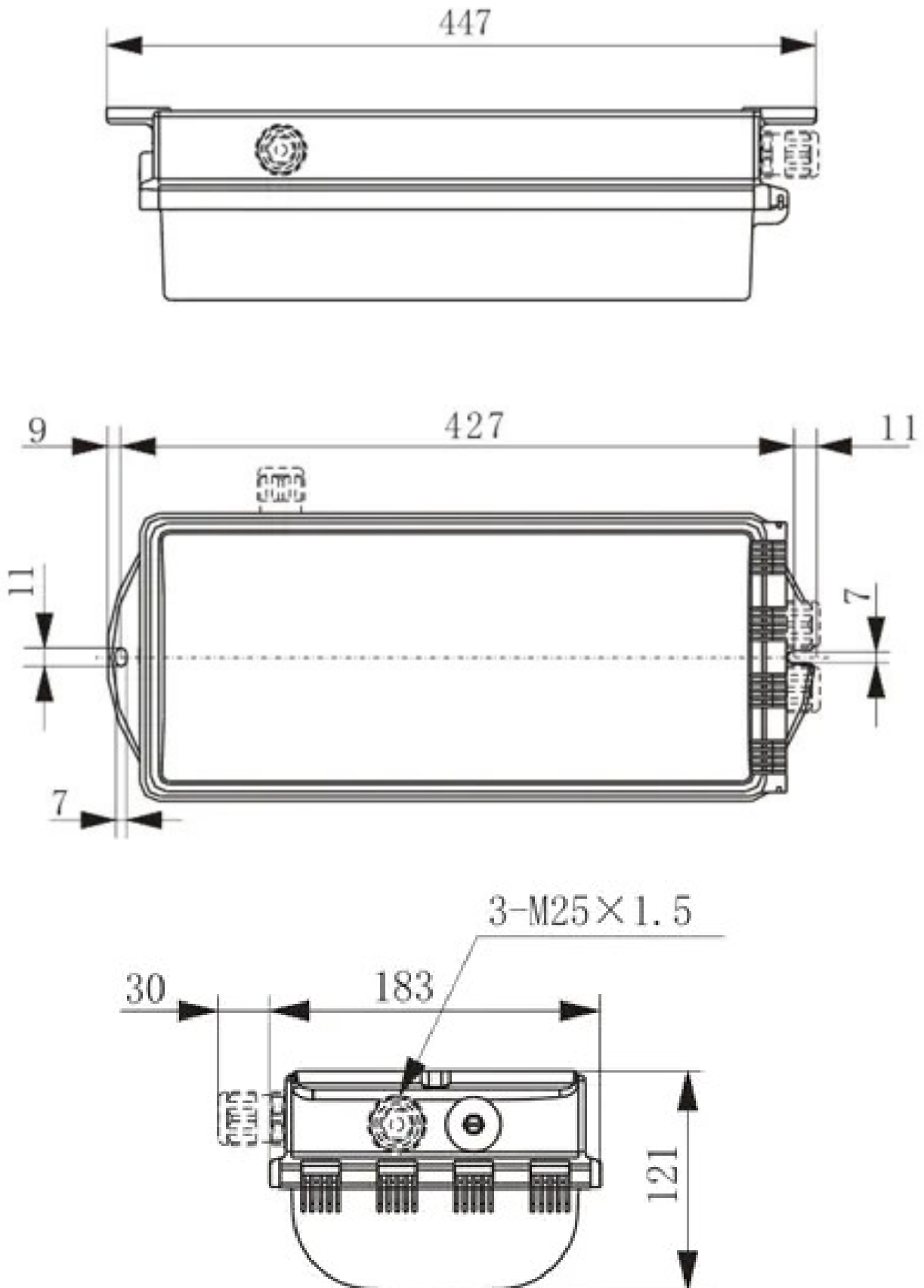

Contact

info@first-automation.com.eg/ • 01101619222 – 01100200886 • <https://first-automation.com.eg/>



فرست اوتوماشن

# LED Marking Light

Series CZ0264 /31

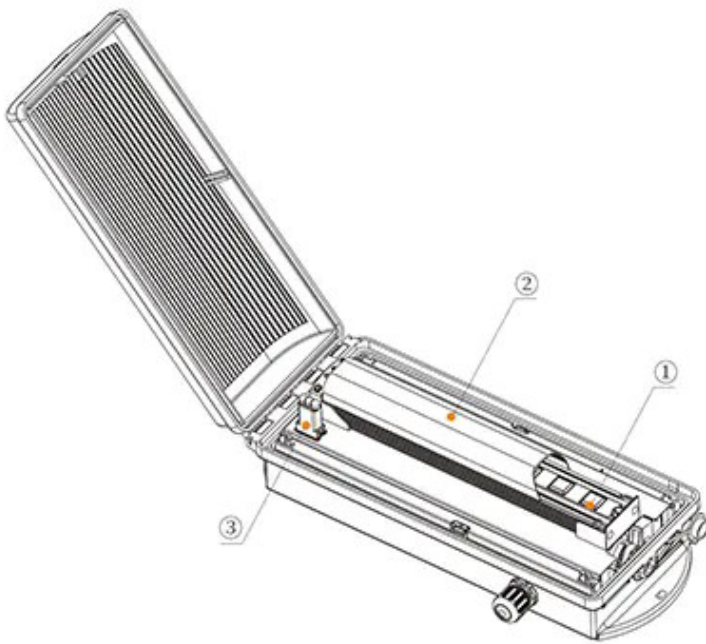

CZ0264/31

Explosion-proof LED linear light fittings

- ① LED light source module
- ② Diffuser ( optional )
- ④ Explosion-proof power supply module
- ⑦ Explosion-proof fuse module ( optional )
- ⑧ Explosion-proof isolation switch module ( optional )

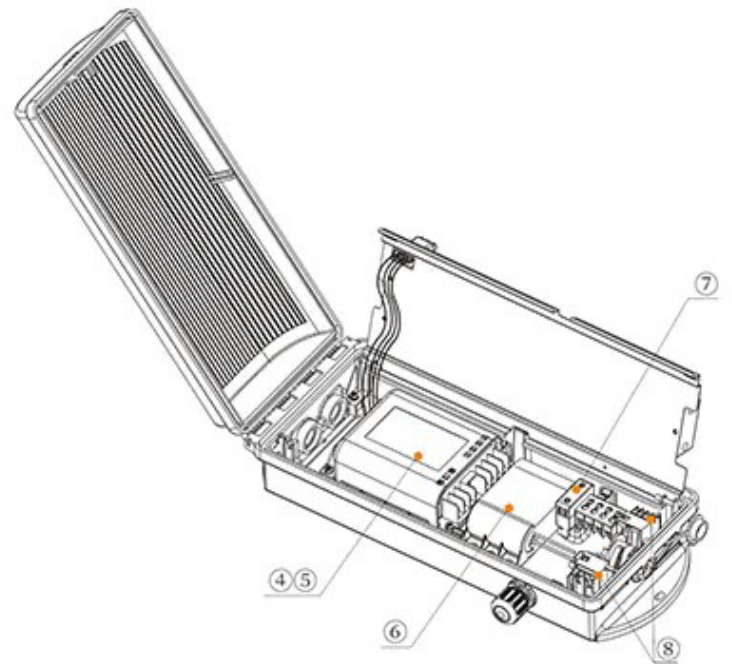

CZ0264/31

Explosion-proof LED emergency linear light fittings

- ① LED light source module
- ② Diffuser ( optional )
- ③ Explosion-proof indicator
- ⑤ Explosion-proof inverter module
- ⑥ Explosion-proof battery module
- ⑦ Explosion-proof fuse module ( optional )
- ⑧ Explosion-proof isolation switch module ( optional )



فرست اوتوماشن

# LED Marking Light

Series CZ0264 /31



Mounting circuit diagram for emergency light fittings:

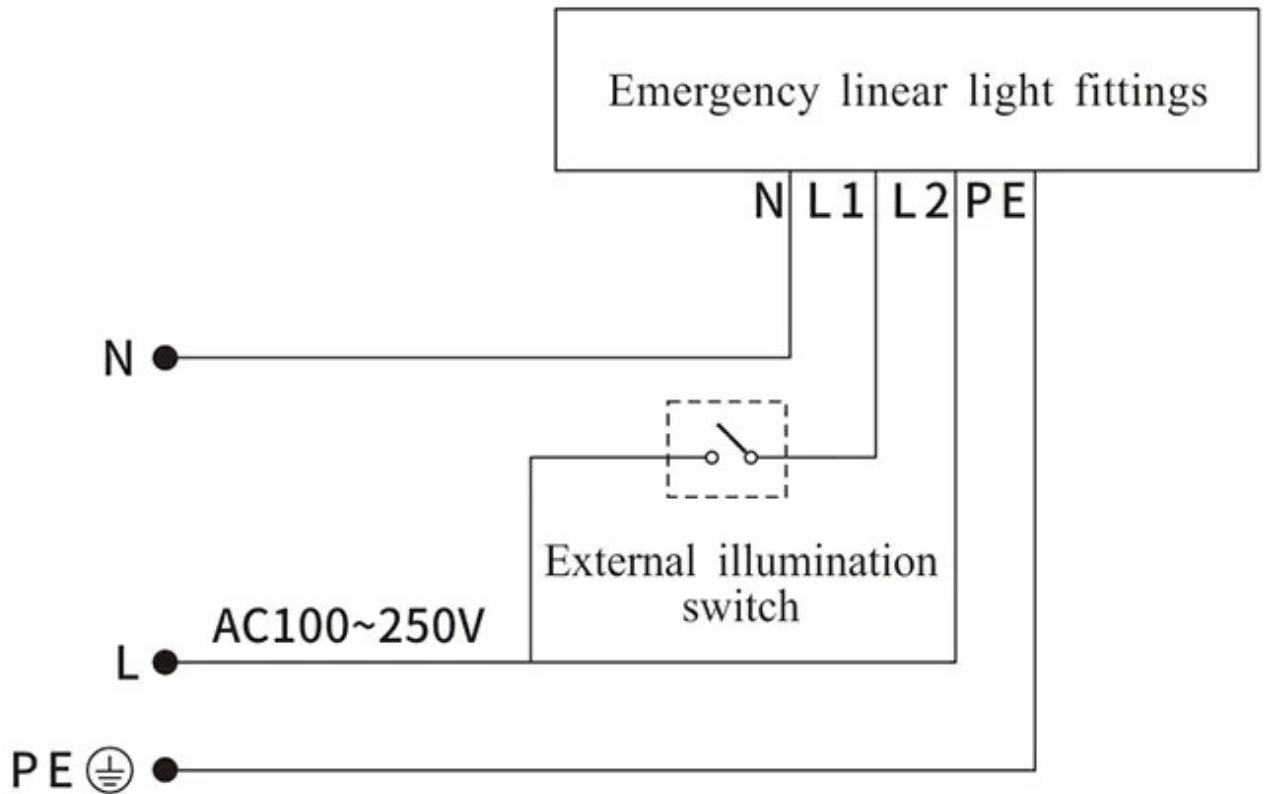





فرست اوتوماشن

# LED Marking Light

Series CZ0264 /31



Illustration	Order No.
 CZ0264/31 Explosion-proof LED linear light fittings	<b>CZ0264/31-LED16W1-B</b>
	<b>CZ0264/31-LED16W2-B</b>
	<b>CZ0264/31-LED16W1-FK-B</b>
	<b>CZ0264/31-LED16W2-FK-B</b>
 CZ0264/31 Explosion-proof LED emergency linear light fittings	<b>CZ0264/31-LED16W1-YJ-B</b>
	<b>CZ0264/31-LED16W2-YJ-B</b>
	<b>CZ0264/31-LED16W1-YJ-FK-B</b>
	<b>CZ0264/31-LED16W2-YJ-FK-B</b>





فرست اوتوماشن

# LED Marking Light

Series CZ0264 /31



## Optional Ex components



| CZ0220 Series Plastic stopping plugs, the reducer



| CZ0221 Metal cable glands



| CZ0220 Series Plastic cable glands, stopping plugs



| CZ0226 Increased safety cable glands



| CZ0527, CZ1725/27 Increased safety breathing, drainage valve



| CZ0227 Increased safety metal cable glands



| CZ1725/1C Metal cable glands



| CZ1725/2A Metal cable glands



| CZ1725/3A Metal stopping plug



| CZ1725/1A Metal cable glands



| CZ1725/4A The reducer



| CZ1725/1B Metal cable glands



فرست اوتوماشن

# LED Marking Light

Series CZ0264 /31



## Accessories



Explosion-proof isolation switch module  
Order No.: CZ0207-1

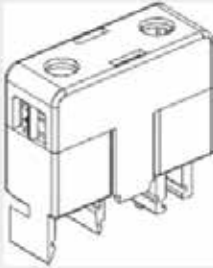

Explosion-proof fuse module  
Order No.: CZ0804 / T0.8A  
CZ0804 / T1.25A  
CZ0804 / T6.3A



Explosion-proof LED light source module  
Order No.: CZ1618/11-LED16W1  
CZ1618/11-LED16W2



Explosion-proof power supply module  
Order No.: CZ1618/57-1×LED16W

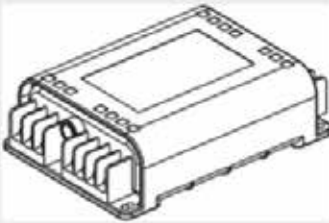

Explosion-proof inverter module  
Order No.: CZ1618/58-1×LED16W

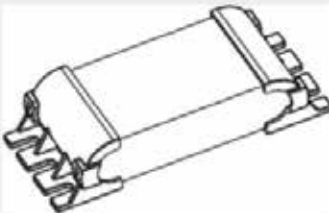

Explosion-proof battery module  
Order No.: CZ0819/1.0Ah/7.2V





فرست اوتوماشن

# LED Marking Light

Series CZ0264 /31



## Accessories

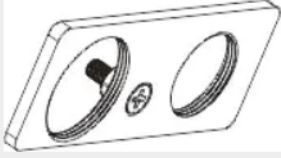

Earthing nut  
Order No. : D8714/2-M25

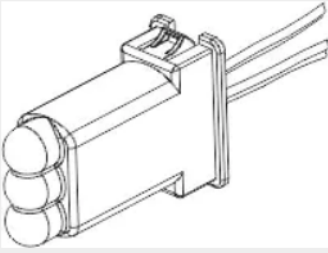

Explosion-proof emergency  
indicator module  
Order No. : CZ0802/1

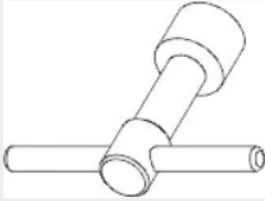

M8/SW13 Sleeve spanner  
Order No.: D601